

Solutions for Leading Edge Detection



BANNER[®]

What is Leading Edge Detection?

What is Leading Edge Detection?

On equipment that moves a product, container, or package, sensors are used to detect the movement or presence of these items to make critical decisions. Specifically, these applications rely on detecting the leading edge of the item as quickly and as accurately as possible.

Challenges of Leading Edge Detection

Types of Containers/Packaging

Trends in packaging have migrated from boxes to more challenging targets. Polybags, Blister packs, envelopes, totes, and tubes are all commonly transported on conveyor lines and can have irregular shapes. As a result, sensing solutions need to be adapted to reliably detect a product.

Types of Conveyors/Equipment

There are many different types of conveyors and machines used to move goods. Some machines can use certain types of sensors while others may not.



Single-Point
Leading Edge Detection



Small and Flat Object
Leading Edge Detection



Wide-Beam
Leading Edge Detection



Through the Roller
Leading Edge Detection







Robust Array
Leading Edge Detection

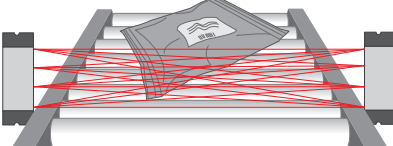
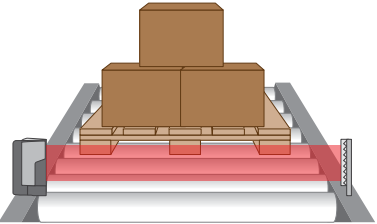

Choosing a Banner Sensor

Choosing the right sensor can reduce errors caused by product jamming, overlapping, side-by-side, and irregular shaped packages.

<p>Single-Point Leading Edge Detection</p> 	<p>Small and Flat Object Leading Edge Detection</p> 	<p>Wide-Beam Leading Edge Detection</p> 
<p>QS18 or Q20</p> 	<p>LX</p> 	<p>Q76E</p> 
<p>Cost-effective yet powerful, these compact sensors detect boxes, totes, and many other objects.</p>	<p>Short response time and large detection area creates an accurate solution for very small or flat objects.</p>	<p>Wide sensing beam detects items like pallets, polybags, or other irregularly shaped objects.</p>

Through the Roller
Leading Edge Detection

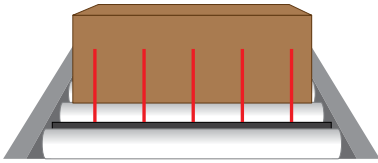

Robust Array
Leading Edge Detection

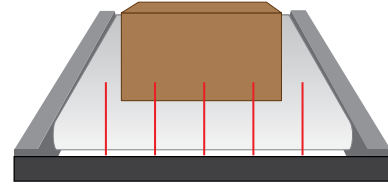

TTR



SAB



An improved solution for roller conveyors, this sensor mounts easily between rollers, detecting a variety of objects.

Heavy-duty sensor bar suitable for tough environments such as sorter chutes and roller conveyors.



Single-Point Leading Edge Detection

- Lowest cost solution
- Sufficient for many targets
- Used on conveyors with rails on the sides
- Robust sensing solution that only requires power on one side of the conveyor
- Polarization assures reliable detection of highly reflective objects

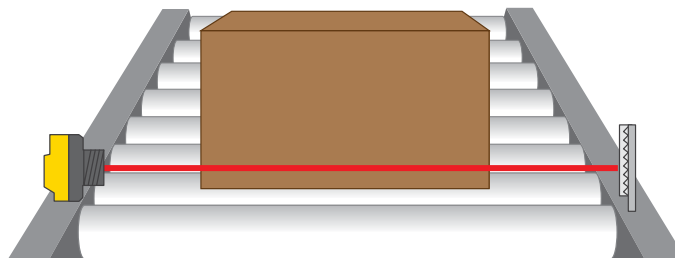

Polarized Retroreflective Sensors

- Polarization assures reliable detection of highly reflective objects
- Fast response speed, less than 1 ms, for excellent sensing repeatability
- Features bright LED operating status indicators visible from 360°



QS18 All-Purpose Photoelectric Sensor

- Universal housing design with 18 mm threaded lens makes an ideal replacement for hundreds of other sensor styles

Models	Sensing Mode	Sensing Range	Connector	Output
QS18VN6LPQ8	630 nm Visible Red	3.5 m (12 ft)	4-pin Euro M12 integral QD	NPN
QS18VP6LPQ8				PNP

* Integral QD connector listed. Cabled and other models available on our website.



Q20 Industry Standard Global Housing

- Rectangular Housing for versatile mounting with M3 threaded inserts with 25.4 mm hole spacing

Models	Sensing Mode	Sensing Range	Connector	Output
Q20PLPQ7	645 nm Visible Red	4 m (13 ft) (specified using reflector BRT-84)	4-pin Pico M12 integral QD	PNP
Q20NLPQ7				NPN

* Integral QD connector listed. Cabled and other models available on our website.

Specifications

	QS18	Q20
Response Speed	850 μ s	850 μ s
Environmental Rating	IEC IP67	IEC IP67
Construction	ABS Housing	ABS Housing

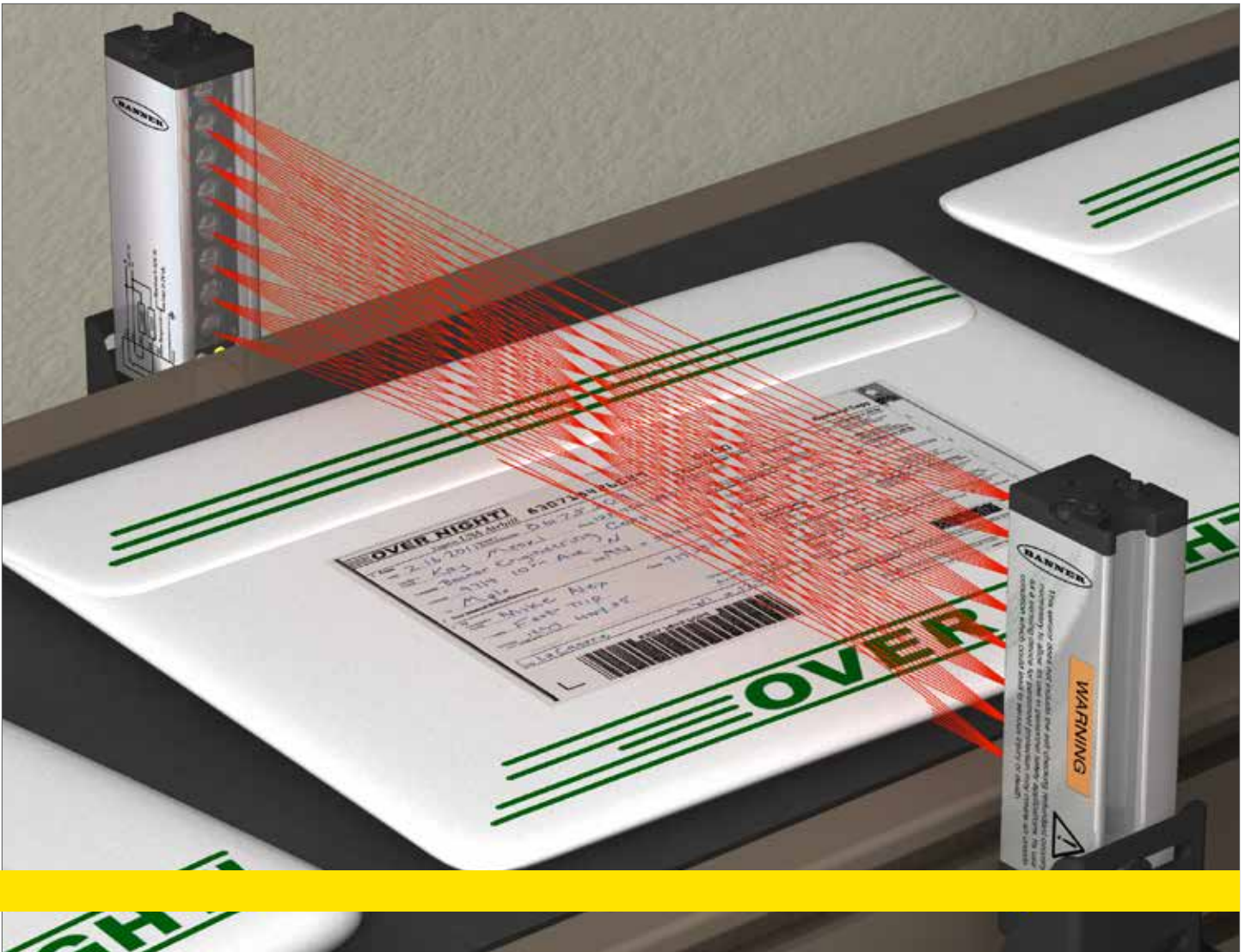

Small or Flat Leading Edge Detection

- Crosshatch beam pattern detects very small or flat packages
- Durable housing design resists damage
- High-speed, response time as fast as 0.8 milliseconds

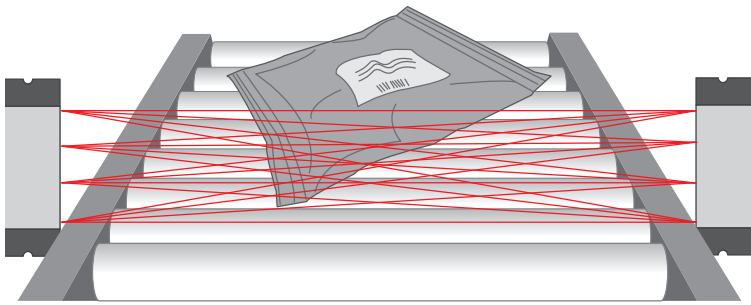



LX Small and Flat Object Detection Sensor

- Large detection area to provide consistent detection of packages where the leading edge varies
- Generates a cross hatched beam pattern that can detect an object as thin as 1 mm, depending on the width
- Response speeds as fast as 0.8 ms allows automated systems to operate at higher line speeds resulting in increased throughput

Models	Response Time	Sensing Array Length	Output Type	Cable*
LX3E Emitter LX3R Receiver	0.8 ms ON-time 6 ms OFF-time (5 ms OFF-delay)	67 mm (2.6 in)	Bipolar NPN/PNP	2 m (6.5 ft) 5- wire Integral cable
LX6E Emitter LX6R Receiver	1.6 ms ON-time 7 ms OFF-time (5 ms OFF-delay)	143 mm (5.6 in)		
LX9E Emitter LX9R Receiver	2.4 ms ON-time 7.5 ms OFF-time (5 ms OFF-delay)	218 mm (8.6 in)		
LX12E Emitter LX12R Receiver	3.2 ms ON-time 8.5 ms OFF-time (5 ms OFF-delay)	295 mm (11.6 in)		
LX15E Emitter LX15R Receiver	4.0 ms ON-time 9 ms OFF-time (5 ms OFF-delay)	371 mm (14.6 in)		
LX18E Emitter LX18R Receiver	4.8 ms ON-time 10 ms OFF-time (5 ms OFF-delay)	447 mm (17.6 in)		
LX21E Emitter LX21R Receiver	5.6 ms ON-time 11 ms OFF-time (5 ms OFF-delay)	523 mm (20.6 in)		
LX24E Emitter LX24R Receiver	6.4 ms ON-time 11.5 ms OFF-time (5 ms OFF-delay)	599 mm (23.6 in)		
LX27E Emitter LX27R Receiver	7.2 ms ON-time 12 ms OFF-time (5 ms OFF-delay)	686 mm (27.0 in)		
LX30E Emitter LX30R Receiver	8.0 ms ON-time 13 ms OFF-time (5 ms OFF-delay)	762 mm (30.0 in)		
LX33E Emitter LX33R Receiver	8.8 ms ON-time 14 ms OFF-time (5 ms OFF-delay)	838 mm (33.0 in)		
LX36E Emitter LX36R Receiver	9.6 ms ON-time 15 ms OFF-time (5 ms OFF-delay)	914 mm (35.9 in)		

* Integral cable models are listed.

- To order the 5-pin M12/Euro-style 150 mm (6 in) cable model, add suffix "Q" to model number (for example, LX3EQ).
- Models with a quick disconnect require a mating cordset.

Specifications

Sensing Range	Short-Range Models: 75 to 150 mm (3 in to 6 in) or 100 to 200 mm (4 in to 8 in); depending on mode Standard-Range Models: 150 mm to 600 mm (6 in to 24 in) or 300 mm to 2 m (1 ft to 6.5 ft); depending on mode
Environmental Rating	Meets IEC IP65
Construction	Aluminum housing, die cast zinc with black e-coat painted endcaps, acrylic lens window



Wide-Beam Leading Edge Detection

- Detects irregular-shaped objects
- Retroreflective sensor, only requires wiring on one side

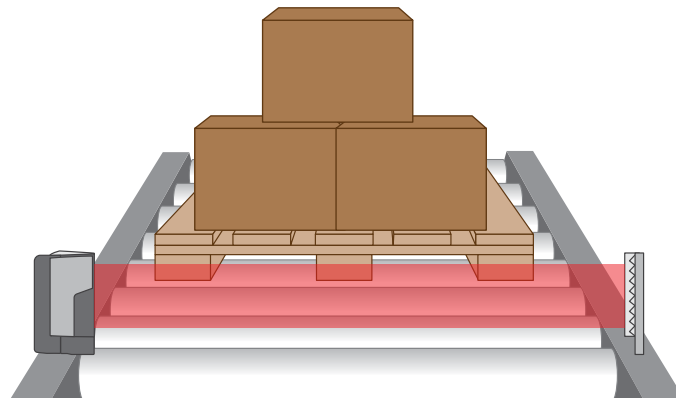



Q76E Wide Beam Retroreflective Sensor

- Wide beam retroreflective sensor for reliable leading edge detection of irregular shaped objects or pallets
- Visible red beam for simple alignment and bright LEDs for visual indication
- Up to 4 meter range for mounting flexibility
- Two sensitivity levels for detection of challenging targets such as shrink wrapped pallets, small objects and film or perforated packaging
- Easy set-up, adjustment and LO/DO selectable via single push button
- 250 Hz switching frequency for high speed production lines
- IP67- and IP69-rated for washdown applications

Models	Range	Input	Output	Cable		
Q76E-VP-ZLVC-Q5	0.4 mm to 4.0 m (1.3 to 13.1 ft)	10 to 30 V DC	Complementary PNP	200 mm (7.5 in) PUR cable with a 4-pin M12/ Euro-style male quick disconnect		
Q76E-VP-ZLVC-Q8				Integral 4-pin M12/Euro-style male quick disconnect		
Q76E-VP-ZLVC-2M				2 m (6.5 ft) unterminated 3-wire PVC cable		
Q76E-VN-ZLVC-Q5			0.4 mm to 4.0 m (1.3 to 13.1 ft)	10 to 30 V DC	Complementary NPN	200 mm (7.5 in) PUR cable with a 4-pin M12/ Euro-style male quick disconnect
Q76E-VN-ZLVC-Q8						Integral 4-pin M12/Euro-style male quick disconnect
Q76E-VN-ZLVC-2M						2 m (6.5 ft) unterminated 3-wire PVC cable
Q76E-KP-ZLVC-Q5					1 PNP/NPN Light Operate with IO-Link; 1 PNP Dark Operate	200 mm (7.5 in) PUR cable with a 4-pin M12/ Euro-style male quick disconnect

Specifications

Range	4 m			
Response Time	2 ms			
Minimum Object Detection Size	Sensitivity Setting	Max. Range 100x100 Reflector	Max. Range 40x60 Reflector	Minimum Object Detection Size
	Standard	4.0 m	3.0 m	19 mm
	Increased	4.0 m	3.0 m	12 mm
	Increased with Fine Adjustment	4.0 m	3.0 m	8 mm
Environmental Rating	IEC IP67, IEC IP69			
Construction	PC-PBT Housing; PMMA Lens Cover			



Through-the-Roller Leading Edge Detection

- Designed for roller conveyors without sides for mounting sensors
- Detects irregularly shaped items
- Large items can knock sensors off sides of conveyors

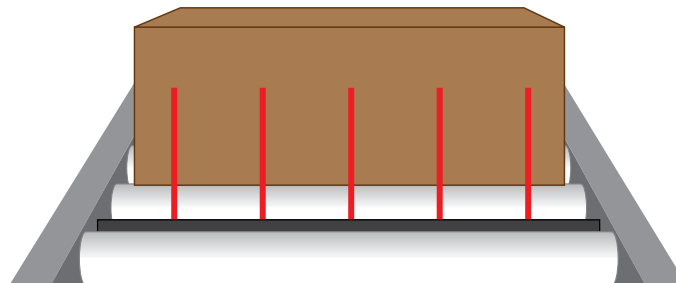



TTR Through The Roller Sensor

- Reliable leading-edge detection of letters, thin packages, poly bags, totes, boxes or other product on roller conveyors
- Mounts between conveyor roller gap to standard hex or round side rail holes with no extra hardware required or on the T-Slot with customer supplied bracket and hardware
- Spring loaded end caps reduce installation and alignment time for reduced labor costs
- Built to order with specified length and beam spacing: 200 to 964 mm (8 to 38 inches) with 2 to 7 sensors for maximum flexibility
- Robust aluminum housing, ambient light and ESD resistance for enhanced durability

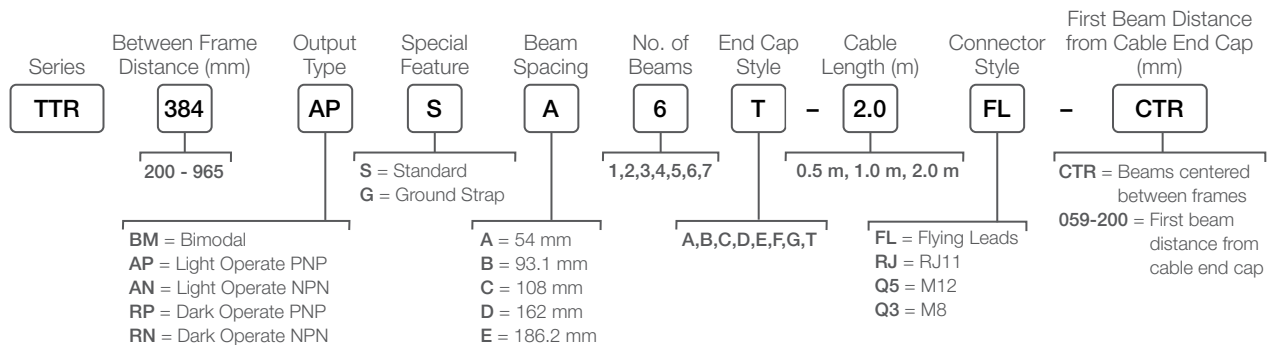

Specifications

Range	120 mm
Output Types	NPN, PNP, Bimodal
Number of Beams	2 minimum - 7 maximum
Maximum Length	965 Standard
Response Time	1 µs ON/OFF
Minimum Object Detection Size	54 mm Beam Spacing - 2" x 2" 93.1 mm Beam Spacing 4" x 4" 162 mm Beam Spacing 6" x 6"
Environmental Rating	IEC IP50
Construction	Aluminum Housing



Robust Array Leading Edge Detection

- Heavy-duty design protects from impact
- Ideal for detecting items moving down a chute
- Diffuse and Retroreflective modes available to accommodate a variety of applications
- Longer sensing range than TTR

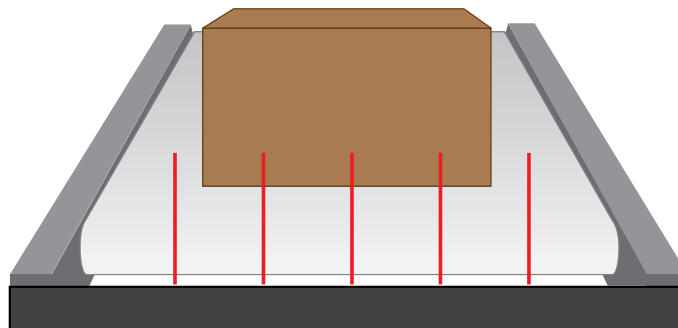



SAB Sensor Array Bar

- Customizable Sensor Array Bar — Different lengths and number of sensors
- Robust aluminum housing protects array bars from challenging environments
- One M12 connector powers the entire array bar and consolidates all outputs into one
- Polarized retroreflective, long-range diffuse, or standard diffuse array bars are available
- IEC rating of IP50
- Solid-state bipolar outputs (NPN and PNP)

Models	Beams	Supply Current	Sensing Range	Sensing Mode	Output
SAB-497RB1LP6-Q5E	6	150 mA	1 m (39 in) when using a BRT-THG-2 reflector tape as a target 3 m (118 in) when using 5 side-by-side BRT-92x92C reflectors or 6 side-by-side BRT-77x77C reflectors as targets	Polarized Retroreflective, Visible Red 624 nm	Dark Operate, Bipolar
SAB-497AB1LP6-Q5E	6	150 mA			Light Operate, Bipolar
SAB-998RB1LP13-Q5E	13	150 mA			Dark Operate, Bipolar
SAB-484RB1LP10-Q5E	10	150 mA			Dark Operate, Bipolar
SAB-497RB1DS6-Q5E	6	150 mA	200 mm (8 in) when using a 90% white card as a target 762 mm (30 in) when using a 90% white card as a target	Diffuse, Infrared, 940 nm	Dark Operate, Bipolar
SAB-497AB1DS6-Q5E	6	150 mA			Light Operate, Bipolar
SAB-998AB1DXL13-Q5E	13	325 mA			Light Operate, Bipolar

Specifications

	Polarized Retro	Diffuse
Range	3 m	762 mm
Response Time	1.5 ms ON/OFF	3 ms ON/OFF
Array Length	135 mm (5.3") minimum, 1219 mm (48") maximum	
Number of Beams	2 minimum, 18 maximum	
Beam Spacing	44.4 mm (1.75") minimum	
Environmental Rating	IEC IP50	
Construction	Black Anodized Aluminum Housing	



Who is Banner?

Every 3.5 seconds, a Banner sensor is installed somewhere in the world. Banner solves problems for most of the manufacturing companies in the Fortune 500, as well as the startups changing industry with leading-edge production.

Banner technology supports manufacturing of the cars you drive, the food you eat, the medicine you take and virtually every product in your daily life. Whatever the industry, Banner offers solutions to automate production, improve efficiency and manufacture to the highest standard of quality.

Manufacturing Specialists

With over 30,000 products, Banner is a leading source for manufacturing needs. We offer award-winning sensors, wireless solutions, vision sensors and lighting, machine safety, indicator lights and LED lighting.

Application Solution Experts

Our field sales engineers are the most highly-trained and experienced professionals in the industry. They can rapidly analyze an application to help you find the best solution.

Global Presence

Banner offers worldwide sales and support through a network of more than 3,000 professionals ready to help you no matter where you are located.

Unique Solutions

Banner's growing product line includes thousands of standard products. However, if you have an application requiring a unique solution or direct integration of a Banner product, contact one of Banner's Application Engineers to learn about our rapid customization and ability to deliver special product variations.

Talk with an app engineer.
Get product specs.
Order now.

